

### Model 850 Whirlpool

The Model 850 Whirlpool is designed to give immersion hydrotherapy to the full body of a patient. It features a stationary Hubbard-design therapy tank with fill and drain components, a pair of carriage-mounted Model 100 Turbines to generate a therapeutic flow of water, a thermometer to measure the temperature of the water, an adjustable headrest, an adjustable body hammock, and a pin stretcher. The whirlpool is U.L./C.U.L. Listed.

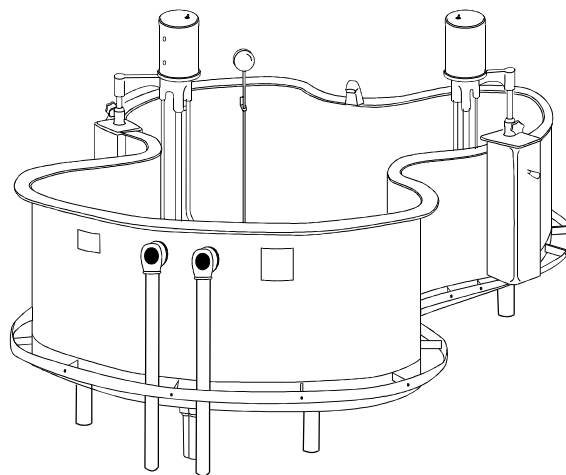

#### Tank

The tank is made of 14 gauge Type 304 stainless steel which is formed, welded, and finished into a one-piece seamless unit. It has a roll-formed rim, vertical walls with embossed marks at 100-gallon intervals, a coved reinforced bottom that slopes toward a drain at the foot end, and 7 support legs.

Water fills the tank through an over-the-rim inlet to prevent backflow. Dual overflows on the tank wall prevent overflowing. Water empties from the tank by gravity through a drain in the tank bottom. Drainage is controlled by a stopper with a pull chain.

#### Thermometer

The thermometer is a sanitary, solid-stem bimetal type with a 3" dial. It is mounted inside the tank, and has a dial range of 40°F to 140°F (5°C to 60°C).

#### Turbines

Each turbine is powered by a 1/3 hp, 3450 rpm electric motor having sealed bearings and thermal overload protection. The motor is connected by a stainless steel shaft to a nylon impeller. The shaft runs inside of a support tube, and is stabilized by a water-lubricated bearing.

An aerator tube injects air into the output stream from the impeller. The shaft-support tube and the aerator tube each have a portal for disinfecting the internal surfaces of the impeller and the aerator.

A manual valve on the impeller-housing inlet controls the impeller output from 0 to 45 gal/min., while a manual valve on the aerator tube controls how much air is injected into the output stream.

Each turbine mounts on a gas cylinder telescoping post attached to a moveable carriage which rolls around the tank rim for perimeter positioning. A friction clamp on the post controls vertical positioning. A twist-lock plug on the turbine cord plugs into a matching receptacle in the carriage. A supply cord on the carriage plugs into a receptacle provided by the user.

#### Optional Accessories

- Mixing Valves & Consoles
- Patient Lifts & Carriers
- Tank & Turbine Products

